



OEM Digital NDIR CO₂ sensor with flow-through gas cell Model 2015SPI-3

The **VALTRONICS** Model 2015SPI-3 is an OEM NDIR CO₂ sensor with digital signal processing and temperature compensation. The firmware VERSION depends upon the specific customer interface requirements. The SPI (Serial Peripheral Interface) is described on pages 2 and 3. Each serial numbered sensor is individually gas calibrated and temperature compensated at the factory. An RS-232 Test Board (which can be connected to a USB port, via an adapter) is needed for field gas calibration & diagnostics (See [Application Note A66](#)). It has on-board & remote switches for calibration. RANGE setting from 3% up to 20% defines 0-1 volt output (see page 4).

Model 2015SPI-3 Specifications:

Method:	NDIR with Digital Signal Processing and Temperature Compensation
Gas:	Carbon Dioxide (CO ₂)
Full-scale and RANGE:	0-20% CO ₂ RANGE user-selectable from 3% to 20%, see page 4
Input Power:	+12 VDC (@ 0.250 amp max, 0.135 amp typical, 16.0 volts max, 8.0 volts min)
Accuracy:	±0.25% CO ₂ from 0 to 5.90% CO ₂ , and 5% of reading from 6% to 20% CO ₂
.....	16-bit analog to digital converter: Delta-Sigma Conversion Method
Resolution / Repeatability:	±0.05% CO ₂ (challenge with same sample gas multiple times & assure zero)
Stability:	Less than 0.05% CO ₂ in any 20-second period of time
Warm-up Time:	Less than 3 minutes for use and 5 minutes for accuracy
Output Signal:	Digital SPI (Serial Peripheral Interface), Application notes A59 and A61
.....	Linear 0 to 1 volt output signal, 12-bit resolution. See pages 3 & 4
RS232 Test Board:	For troubleshooting & gas calibration, see Application note A66
LED Indicators:	IR Source ON/OFF Indicator, Power ON Indicator, Cal Switch Indicators
Input Signal:	Digital SPI input for calibration & diagnostic modes. See Application Note A59
Calibration Switches:	SW1 (Zero), SW2 (Span Target (STAR)), SW3 (Span), SW4 (Range adj.), remote via J3
Operating Temperature Range:	0 to 50°C (32° to 122°F), see Application Note A12
Ambient Relative Humidity: ...	0 to 95% RH non-condensing: see Application note A30
Storage Temperature Range: ...	-40 to +70°C (-40 to 158°F)
Weight:	Less than .25 pound (<.011 kilogram)
External Dimensions (PCB): ...	4.9" x 2.9" x 1.5". See page 2 for mounting

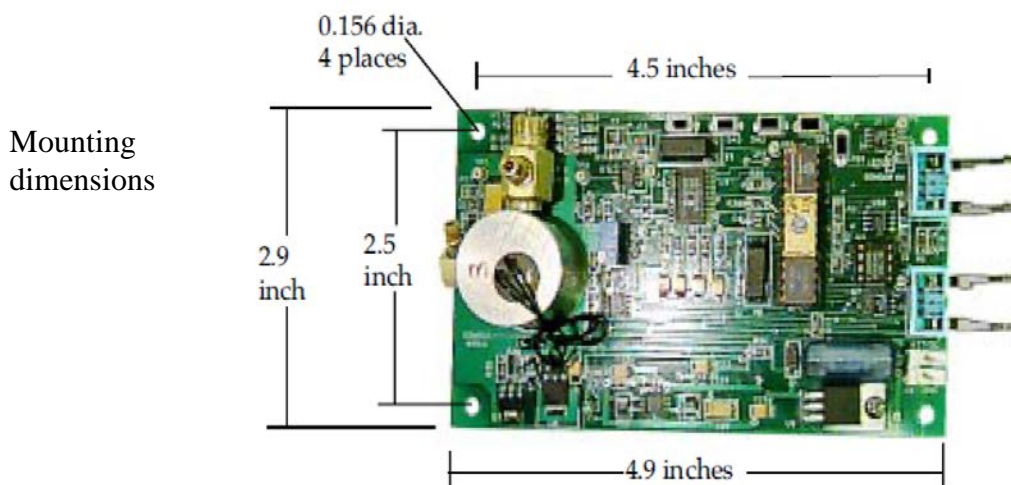
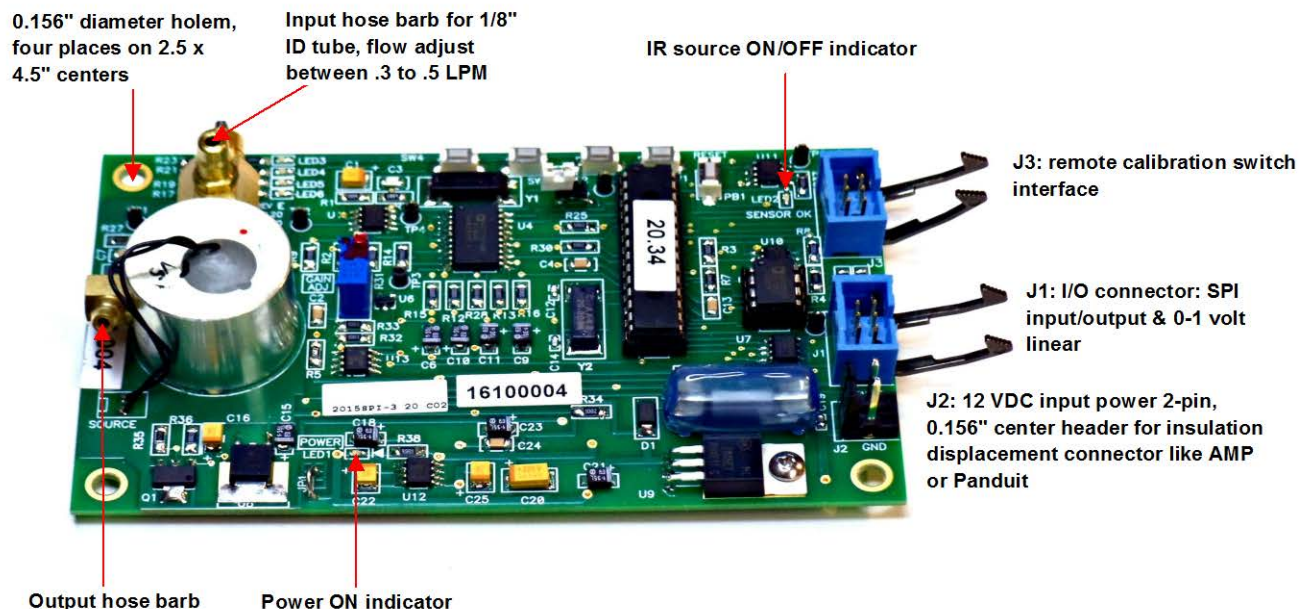

See Application Note A67 for gas conditioning requirements and information about gas sample pumps and filters. A Hydrophobic filter (App Note A79) in front of the inlet hose barb is required to prevent particles & droplets from entering the gas cell. Try to minimize the backpressure inside the gas cell.

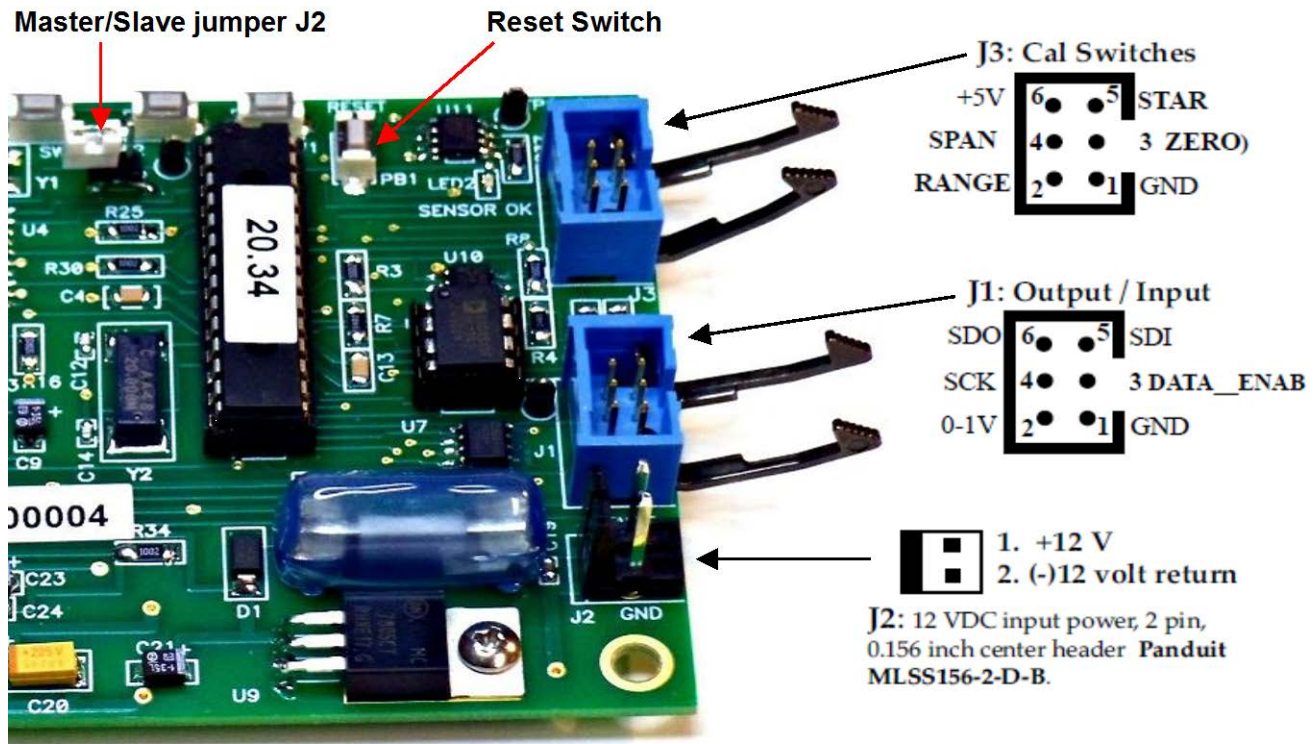

See Application Note A75 for J1, J2 & J3 mating connector part numbers. Keep J1 interface cable shorter than 18". See Application Note A61 for 16-bit serial digital output timing diagram.

Gas calibration may be initiated via a command from the SPI input on J1 (see Application Note A59) or from the on-board or remote switches via J3 (Logic "0" to initiate).

For the locations of the on-board switches, test points and LEDs 3 - 6, refer to the illustration on the next page.

ZERO (SW1 or remote J3-3): With nitrogen flowing in gas calibration tube press and hold SW1 for 2 seconds. LED 3 through 6 will flash on & off together. If they flash on/off sequentially the sensor has detected an error and the RESET button must be pressed. Wait 1 minute and continue where you left off. The 0 to 1 volt output should snap to 0.0 ±0.01 volt measured with a DVM "+" lead connected to TP7 and "-" lead connected to GND test point. LED 3 will be ON to indicate a ZERO calibration.

RANGE (SW4 or remote J3-2): To set the full scale or range press and hold SW4. From the chart on page 5, find the voltage value that corresponds to the full scale that you want from 3 to 20%. LED 6 will be ON. Use SW1 as an UP and SW3 as a DOWN switch to adjust this value (examples: 20% = 1.00 v, 10% = 0.50 v, 3% = 0.15 v).

STAR (SW2 or remote J3-5): To set the Span Target (calibration gas value) press and hold SW2. LED 4 will be ON. Use SW1 as an UP and SW3 as a DOWN switch to adjust this value read on the DVM. See chart on page 5.

SPAN (SW3 or remote J3-4): To SPAN calibrate while flowing certified span gas (like 5.0 ±0.01% CO²) in gas calibration tube for at least 30 seconds at about 300 ml/min. Press & hold SW3 for 2 seconds. LED 5 will be ON. The DVM voltage should snap to the STAR value entered above & LED 3 through 6 will flash on & off together.

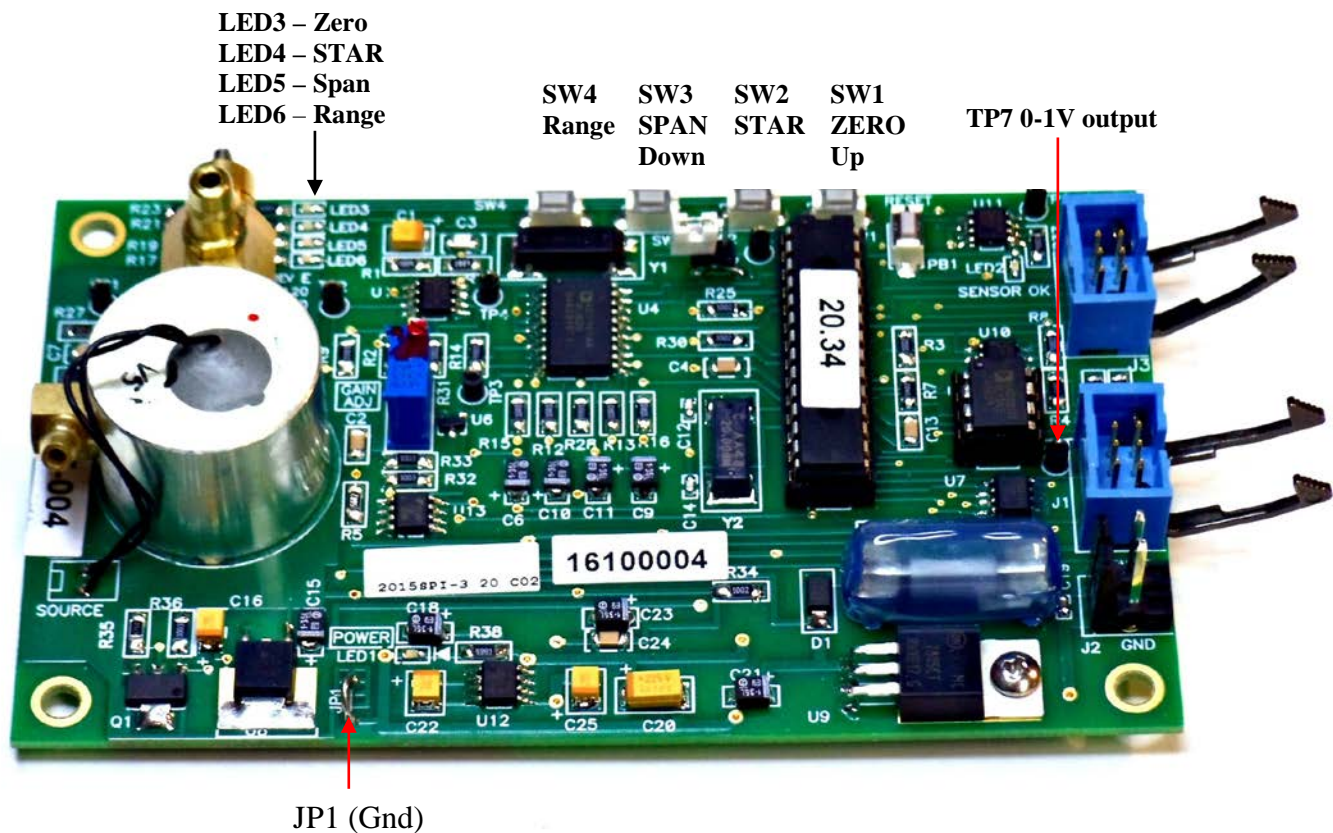

On the next page is a table that shows the 0 to 1 volt output equivalent to any Full Scale **RANGE** or Span **TARGET (STAR)** anywhere from 3 to 20% CO₂. Version 20.34 or later allows a **STAR** to be as low as **1.00%** CO₂. The ideal Span **TARGET** gas for best accuracy is near mid-scale, like **10.0 ±0.2%** certified CO₂, or near your typical measurement point. A typical application would be a full-scale **RANGE** of **20.0** and a **STAR** of **5.00**. If the serial digital output is used (see App Note A61) the **RANGE** value does not affect it. The serial digital output has a 16-bit resolution over the whole 0 to 20% scale.

The Full-Scale **RANGE** will set **what % CO₂** will give an output of **1.00 volt**.

A Range of 3.0 will give a 0-1V output of **0.500** volt for a gas reading of **1.5%** CO₂.

A Range of 5.0 will give a 0-1V output of **0.500** volt for a gas reading of **2.5%** CO₂.

A Range of 20.0 will give a 0-1V output of **0.250** volt for a gas reading of **5.0%** CO₂.

In other words, the 0-1V output is a decimal representation of the percent of full scale: for a Range of 20.0, 5.0% gas is 1/4 or 25% of the full-scale (5 divided by 20), which is a decimal value of .25, which would be .250 volt. 10% gas is 1/2 or 50% of the full-scale, which is a decimal value of .5, which would be .500 volt.

Please remember that **calibration** using the **RS-232 Test Board** will give the user much better visibility as to what **RANGE** and what **STAR** value is selected¹. **Version 20.34** or later allows a **STAR** to be as low as **1.00%** CO₂.

¹ Most computers nowadays do not have an RS-232 port, so a RS-232 to USB adapter would be needed.



Model 2015SPI-3

Table used for **Calibration** for setting the Full-Scale & the Span **TAR**get value, **STAR** (certified tank %).

Range/STAR	0 to 1V	Range/STAR	0 to 1V	Range/STAR	0 to 1V	Range/STAR	0 to 1V
% gas	Ouput	% gas	Ouput	% gas	Ouput	% gas	Ouput
20.0	1.000	15.0	0.750	10.0	0.500	5.0	0.250
19.9	0.995	14.9	0.745	9.9	0.495	4.9	0.245
19.8	0.990	14.8	0.740	9.8	0.490	4.8	0.240
19.7	0.985	14.7	0.735	9.7	0.485	4.7	0.235
19.6	0.980	14.6	0.730	9.6	0.480	4.6	0.230
19.5	0.975	14.5	0.725	9.5	0.475	4.5	0.225
19.4	0.970	14.4	0.720	9.4	0.470	4.4	0.220
19.3	0.965	14.3	0.715	9.3	0.465	4.3	0.215
19.2	0.960	14.2	0.710	9.2	0.460	4.2	0.210
19.1	0.955	14.1	0.705	9.1	0.455	4.1	0.205
19.0	0.950	14.0	0.700	9.0	0.450	4.0	0.200
18.9	0.945	13.9	0.695	8.9	0.445	3.9	0.195
18.8	0.940	13.8	0.690	8.8	0.440	3.8	0.190
18.7	0.935	13.7	0.685	8.7	0.435	3.7	0.185
18.6	0.930	13.6	0.680	8.6	0.430	3.6	0.180
18.5	0.925	13.5	0.675	8.5	0.425	3.5	0.175
18.4	0.920	13.4	0.670	8.4	0.420	3.4	0.170
18.3	0.915	13.3	0.665	8.3	0.415	3.3	0.165
18.2	0.910	13.2	0.660	8.2	0.410	3.2	0.160
18.1	0.905	13.1	0.655	8.1	0.405	3.1	0.155
18.0	0.900	13.0	0.650	8.0	0.400	3.0	0.150
17.9	0.895	12.9	0.645	7.9	0.395	2.9	0.145
17.8	0.890	12.8	0.640	7.8	0.390	2.8	0.140
17.7	0.885	12.7	0.635	7.7	0.385	2.7	0.135
17.6	0.880	12.6	0.630	7.6	0.380	2.6	0.130
17.5	0.875	12.5	0.625	7.5	0.375	2.5	0.125
17.4	0.870	12.4	0.620	7.4	0.370	2.4	0.120
17.3	0.865	12.3	0.615	7.3	0.365	2.3	0.115
17.2	0.860	12.2	0.610	7.2	0.360	2.2	0.110
17.1	0.855	12.1	0.605	7.1	0.355	2.1	0.105
17.0	0.850	12.0	0.600	7.0	0.350	2.0	0.100
16.9	0.845	11.9	0.595	6.9	0.345	1.9	0.095
16.8	0.840	11.8	0.590	6.8	0.340	1.8	0.090
16.7	0.835	11.7	0.585	6.7	0.335	1.7	0.085
16.6	0.830	11.6	0.580	6.6	0.330	1.6	0.080
16.5	0.825	11.5	0.575	6.5	0.325	1.5	0.075
16.4	0.820	11.4	0.570	6.4	0.320	1.4	0.070
16.3	0.815	11.3	0.565	6.3	0.315	1.3	0.065
16.2	0.810	11.2	0.560	6.2	0.310	1.2	0.060
16.1	0.805	11.1	0.555	6.1	0.305	1.1	0.055
16.0	0.800	11.0	0.550	6.0	0.300	1.0	0.050
15.9	0.795	10.9	0.545	5.9	0.295	0.9	0.045
15.8	0.790	10.8	0.540	5.8	0.290	0.8	0.040
15.7	0.785	10.7	0.535	5.7	0.285	0.7	0.035
15.6	0.780	10.6	0.530	5.6	0.280	0.6	0.030
15.5	0.775	10.5	0.525	5.5	0.275	0.5	0.025
15.4	0.770	10.4	0.520	5.4	0.270	0.4	0.020
15.3	0.765	10.3	0.515	5.3	0.265	0.3	0.015
15.2	0.760	10.2	0.510	5.2	0.260	0.2	0.010
15.1	0.755	10.1	0.505	5.1	0.255	0.1	0.005

To check what RANGE (Full-Scale for 0-1 volt output) is selected, press and hold SW4 (see page 4) and measure the voltage out at TP7. As an example, TP7 will read 0.50 volt for a full-scale RANGE of 10.0% CO₂. The STAR will be relative to the new full scale RANGE. As an example, a STAR of 5.0% CO₂ with a full-scale RANGE of 10% will give a 0 to 1 volt output of 0.5 volt when the STAR switch SW2 is pressed. A STAR of 5.0% CO₂ with a full-scale RANGE of 20% will give a 0 to 1 volt output of .25 volt when the STAR switch SW2 is pressed.

CAUTION: It is easy to get confused when you are pressing these different switches. Please make sure to double-check where you have set the RANGE and STAR. If you attempt to gas calibrate and the STAR does not match the certified gas % when you press the SPAN SW3, the sensor will obviously give you incorrect measurements.

Version 20.33 and later disables the digital and the analog 0 to 1 volt outputs during the first 40 seconds after a power-on RESET to prevent and out-of-range signal from being transmitted.